

STEELCRAFT P/N: SCDHWT42X132

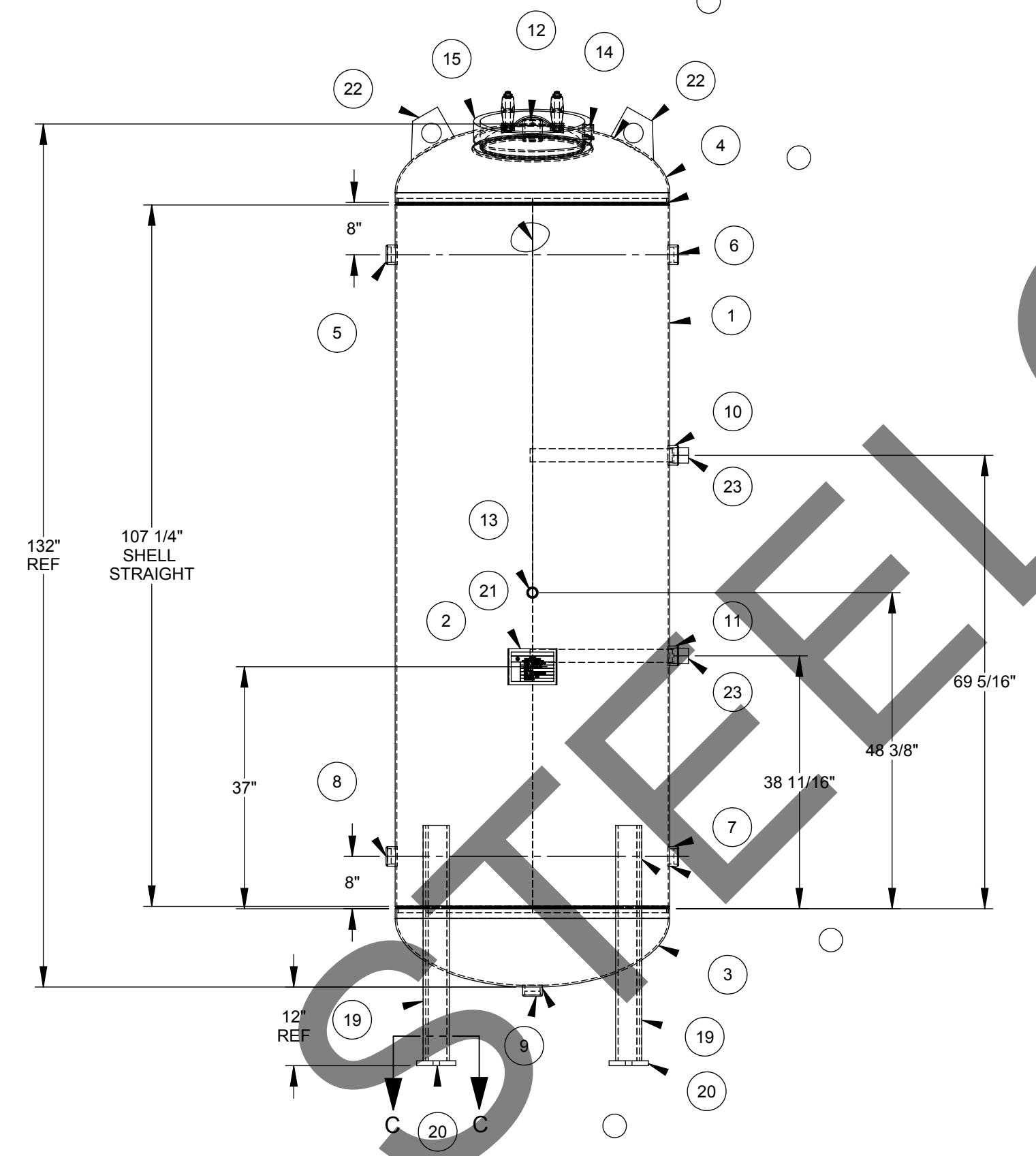
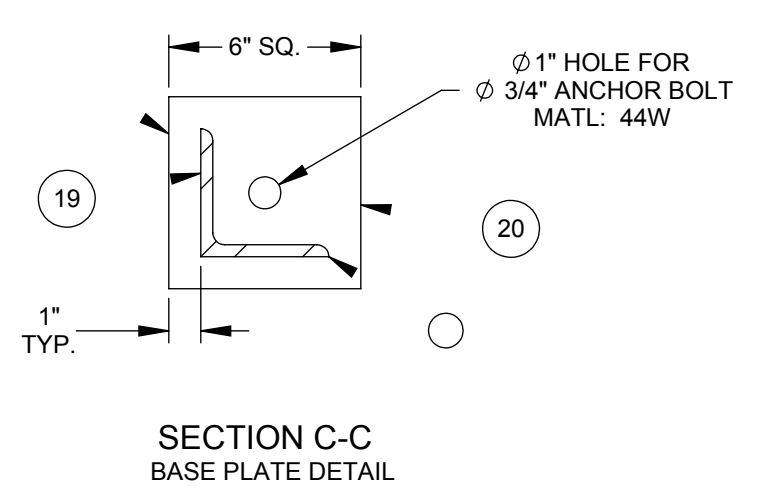
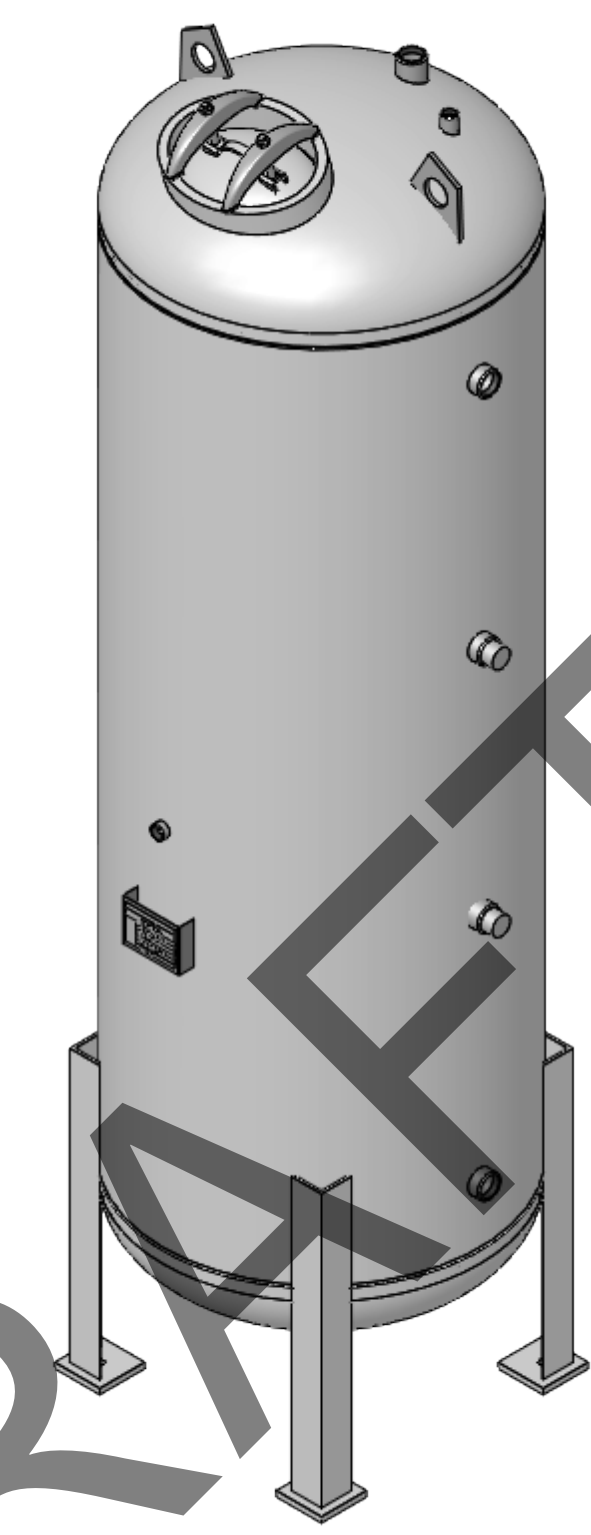
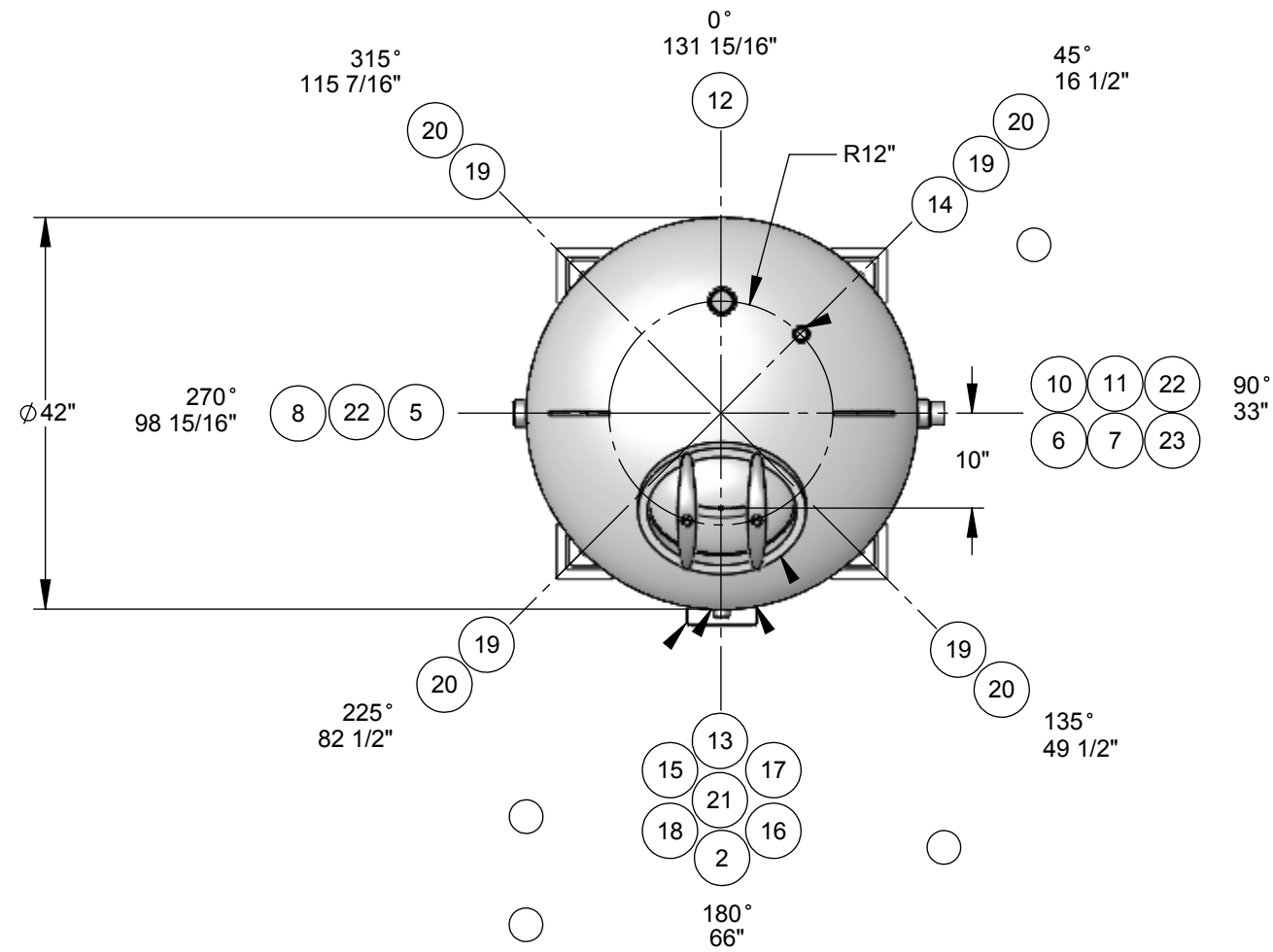

ITEM NO.	QTY.	PART NO.	DESCRIPTION
1	1	A43938-01	Cylinder: 42" O.D. x 109" Lg.
2	1	A43932 - NP	ASME NAMEPLATE
3	1	HDSE042001FJ	Head: S.E., 42" O.D.
4	1	HDSE042001FJ	Head: S.E., 42" O.D.
5	1	CPHT200300XU	Coupling: 2" NPT
6	1	CPHT200300XU	Coupling: 2" NPT
7	1	CPHT200300XU	Coupling: 2" NPT
8	1	CPHT200300XU	Coupling: 2" NPT
9	1	CPHT200300XU	Coupling: 2" NPT
10	1	CPHT200300XU	Coupling: 2" NPT
11	1	CPHT200300XU	Coupling: 2" NPT
12	1	CPFT200300XU	Coupling: 2" NPT
13	1	CPHT100300XU	Coupling: 1" NPT
14	1	CPFT100300XU	Coupling: 1" NPT
15	1	MHCO121640UC	Manway Collar: 12" x 16" x 1" x 4" Wide
16	1	GSKO121600XY	Manway Gasket
17	1	CVRB121615XC	Manway Cover
18	2		Manway Yoke c/w Bolt & Nut
19	4	A43932-L	4" X 4" X 36" LG ANGLE
20	4	A43932-FP	6" X 6" X 3/4" Thk. FOOT PAD WITH 1" HOLE
21	1	BKPL400055XC	Nameplate Bracket
22	2	LLTV050075QC	Lift Lug
23	2	ANDA200220XM	Anode, 2" Screwed Magnesium

Design Specifications

M.A.W.P.: 150 psi
 Design Temperature: 500 °F
 M.D.M.T.: 0°F @ 150 psi
 Impact Testing Exempt per UG-20(f) & UCS-66
 Design External Pressure: 0.0 psi
 Hydrotest Pressure: 195 psi
 Corrosion Allowance: 0.0 in.
 Code: ASME Section VIII, Div. 1 2017
 Approximate Volume: 2591 L
 Approximate Weight: 2498 L
 Material of Construction: Carbon Steel

Finish
 Interior:
 Line with Cement to CSA, NSF/ANSI 61 Standard

Exterior:
 -Primer

Construction Notes

- Bolt holes to straddle centerlines.
- This vessel is designed with superimposed static, dynamic or cyclical reactions due to equipment or mechanical loading, or pressure or thermal variations = 0 lbs.
- This vessel is designed with thermal, mechanical, cyclical, pressure or fluid shock loadings = 0 lbs.
- Round or chamfer all sharp interior corners.
- This vessel is designed to contain a non-lethal gas, vapour or a non-lethal liquid.

TOLERANCES UNLESS OTHERWISE NOTED MACHINING .X = ±.1" .XX = ±.02" .XXX = ±.005" ANGLES ±.5° MAX. MACHINED SURFACE ROUGHNESS 125 MICROINCHES		WELD FABRICATION <=24" = ±1/16" >24" = ±1/8" ANGLES = ± 0.5° 		Engineered Products Division 487 Lorne Avenue East, PO Box 339, Stratford, Ontario N5A 6T1 P. 1.800.387.6537 F. 519.271.1092 www.steelcraftinc.com	
THIS PRINT AND DESIGN ARE THE PROPERTY OF STEELCRAFT INC. AND MUST NOT BE USED TO ITS DETRIMENT.					
PRODUCT: 42" O.D. X 132" HIGH STD PV					
DESCRIPTION: MAIN ASSEMBLY					
COMMENTS: SEE BOM FOR MATERIALS					
DRAWN: PEK DATE: 02/08/2019	CHK'D: NTS DATE: -	SCALE: NTS WEIGHT: 1634	JOB No.: SCDHWT42X132	DRAWING No.: CL43938	SHEET 1 OF 1 REV. No.: 0