

- NOTE:
- FINISH: INTERIOR AS WELDED, EXTERIOR PRIMER or INTERIOR AND EXTERIOR GALVANIZED
  - MATERIAL OF CONSTRUCTION: CARBON STEEL
  - BUILT TO ASME SECTION VIII DIV.1, 'U' STAMP.
  - THIS VESSEL IS DESIGNED WITH NO EXTERNAL LOADINGS.

OVERALL LENGTH 'L' in [mm]	VOLUME ig [ltr]	WEIGHT lbs [Kg]	GAUGE GLASS Qty	150 psig
60 [1525]	191 [868]	585 [265]	1	<b>SCPSET36X060H</b>
72 [1830]	234 [1064]	681 [309]	1	<b>SCPSET36X072H</b>
84 [2135]	277 [1259]	776 [352]	1	<b>SCPSET36X084H</b>
96 [2440]	319 [1450]	872 [396]	1	<b>SCPSET36X096H</b>
108 [2745]	362 [1646]	967 [439]	1	<b>SCPSET36X108H</b>
120 [3050]	405 [1841]	1063 [482]	1	<b>SCPSET36X120H</b>

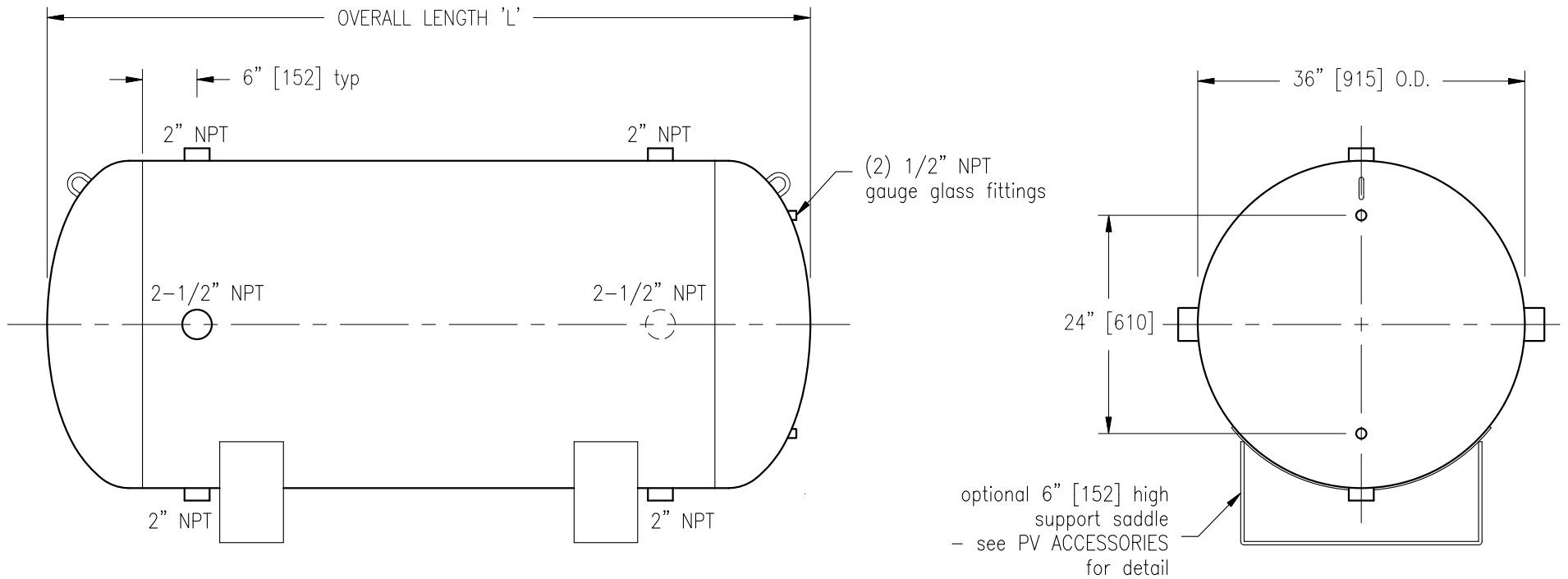

**STEELCRAFT**  
Engineered Products Division

DESCRIPTION:  $\phi$  36" Horizontal Air Cushion/Expansion Tank

CUSTOMER:

PROJECT:

ITEM NO.:

DRN.: HK 13-APR-15

SCALE: NTS

JOB NO.:

DWG. NO.: ACH36



487 Lorne Avenue East, Stratford, ON, N5A 6T1