

\* electrical box w/hinged cover 8"h x 6"w x 4"d (inside dimensions)

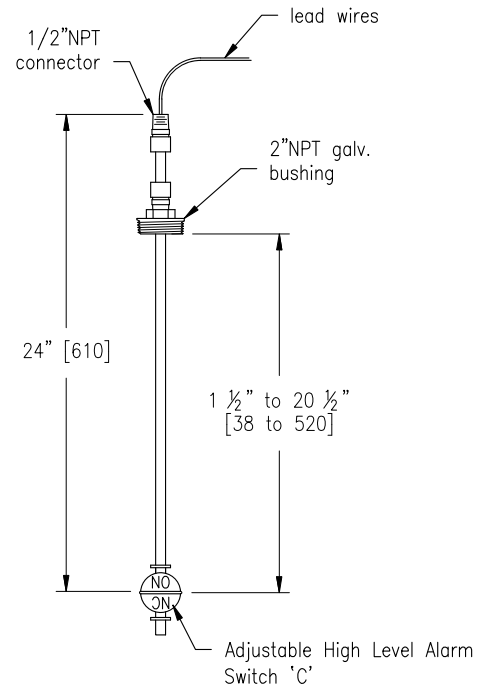

PROCESS CONDITIONS

Max Temp 275 °F (135 °C)  
 Min Temp -40 °F (-40 °C)

SPECIFICATIONS

Float – Material: Stainless Steel  
 Contact Rating: SPST 20 VA  
 ULC Recognized  
 CSA Listed

(Monitor RFLM-1 Part #MNRM000002XX)

(Switch Assembly Part #FSHA120000XS)

NOTE: The RFLM-1 Remote Monitor and Switch assembly is ULC listed.

The Clemmer Model RFLM-1 Remote Monitor is equipped to perform as an audio/visual device for the limiting of the fill level of a single tank. It is acceptable for use in all ULC listed underground and aboveground tanks. The monitor is intended for outdoor installation and is enclosed in a weather tight, quick opening and lockable non-metallic electrical box.

\* See manufacturer's installation instructions for proper connection of tanks or piping to monitor connector terminals.

**STEELCRAFT**  
 Engineered Products Division

DESCRIPTION: MONITOR RFLM-1 & SWITCH

CUSTOMER:

PROJECT:

ITEM NO.: KTMS000000XX

DRN.: HK 5-JUN-13

SCALE: NTS

JOB NO.:

DWG. NO.: KTMS000000XX



## RFLM-1 MONITOR INSTALLATION INSTRUCTIONS

**IMPORTANT: PLEASE READ ALL OF THE INSTRUCTIONS BEFORE ATTEMPTING THE INSTALLATION OF THE RFLM-1 MONITOR, THE FLOAT SWITCH, AND THE 120 VAC / 12 VAC TRANSFORMER.**

The Model RFLM-1 Remote Fill Monitor is an Underwriters' Laboratories of Canada (ULC)-listed overflow protection device in accordance with Class 1 of CAN/ULC-S661-10 and is designed to provide an audio/visual warning when the liquid in a storage tank reaches a pre-set high-level limit.

The model requires the use of a Model FS-1, CSA-listed float switch installed in the tank. The FS-1 float switch is equipped with a normally open reed switch that closes in alarm. The float switch is adjustable, which allows the alarm level to be selected based on the tank diameter and fill rate.

To prevent on/off signaling due to wave action in the tank at time of filling, the RFLM-1 monitor is equipped with a 3-second delay in the alarm mode. The float switch alarm level must be adjusted to accommodate the 3-second delay based on the tank diameter and fill rate.

The RFLM-1 monitor is enclosed in a quick-opening, weather-tight, lockable FRP electrical panel box and is intended to be located outdoors near the fill connection of a storage tank.

The RFLM-1 is powered by a 120 VAC/12 VAC transformer with a 0.5 Amp rating. The transformer is supplied installed in a weather-tight electrical 4" x 4" x 2" PVC box.

### Installation

---

1. Locate the RFLM-1 in accordance with the Float Switch / Monitor mounting diagram included.
2. Locate the power transformer in a convenient location relative to the 120 VAC power source.
3. Locate the float switch in the tank so that it will alarm when the tank is full to 90% of its design capacity; remember to compensate for the 3-second time delay.
4. The float switch is equipped with a male ½" NPT connection for the attachment of an explosion-proof "J" box. Connect the two wires from the float switch to the #1 terminal located inside the 5 x 5 x 2 PVC box in the RFLM-1 Monitor using #18 stranded copper wire and electrical conduit.
5. The industrial transformer is supplied with a center tap wire on the low voltage side of the transformer; the center tap is not used. Connect the two green wires from the low voltage side of the transformer to the 12 VAC terminals in the RFLM-1 Monitor.
6. Connect the high-voltage side of the transformer, the black wires, to the 120 VAC power source. NOTE: A QUALIFIED ELECTRICIAN IS REQUIRED FOR THE HIGH-VOLTAGE CONNECTIONS.
7. After all electrical connections are complete, activate the 120 VAC power source. The green power light on the RFLM-1 Monitor will illuminate. If the power light fails, check the power source and the 1/8 Amp fuse located in the monitor box.

**WARNING:**

**ALL HIGH-VOLTAGE CONNECTIONS MUST BE MADE BY A LICENSED ELECTRICIAN.**

## **Operational Check**

---

The green power light must be on. Press the TEST button on the monitor and hold it for 3 seconds until the horn sounds and the high-level red light comes on. Release the TEST button and the monitor will reset itself.

The float switch has been tested prior to delivery. That said, it is advisable to re-check its operational sequence prior to installation. The check can be completed with an ohmmeter. The switch is normally open in the installed position and will close when the ball is moved upward.

Short the HL terminal and wait for 3 seconds until the horn sounds and the red light comes on. Activate the MUTE switch so that the horn mutes but the red light stays on. Remove the short and the system will reset itself.

## **RFLM-1 Operational Fill Sequence**

---

1. Open weather-tight enclosure to expose the RFLM-1 monitor.
2. Green power light must be on. If the green power light is not on, the monitor is not operational. Check the power source and/or 1/8 Amp fuse in monitor box.
3. Activate the TEST switch and hold for 3 seconds. The high-level light should come on and the horn should sound. If either the high-level light or horn fail to activate, the unit is considered non-operational and maintenance must be scheduled.
4. Where possible, use a dip stick to dip tank, making sure that the empty portion of the tank has the physical capacity to hold the volume of product being delivered.
5. Fill the tank.
6. When the high-level float switch is activated, the alarm will sound and the red light will come on. Stop filling the tank and activate the MUTE switch. At this time, the horn will mute but the red light will remain on. The unit will reset itself when the liquid level drops below the high-level alarm capacity.
7. Close up and secure fastenings on the weather-tight enclosure.

### **WARNING:**

**THE OPERATIONAL CONDITION OF THE IN-TANK FLOAT SWITCH IS NOT CHECKED BY THE TEST PROCEDURE. THE FUEL DELIVERY PERSON CANNOT WHOLLY DEPEND ON THE WARNING SYSTEM TO PROVIDE TANK OVERFILL PREVENTION AND MUST ACCEPT FULL RESPONSIBILITY FOR ANY OVERFILL THAT OCCURS, REGARDLESS OF THE CONDITION OF THE MONITOR.**

**ALTHOUGH THE RFLM-1 IS RATED AS A LOW-VOLTAGE ELECTRICAL DEVICE, IT INCLUDES THE ATTACHMENT OF OTHER DEVICES THAT DIRECTLY ACCESS HIGH-VOLTAGE ELECTRICAL CURRENTS. THESE CONNECTIONS REQUIRE THE USE OF A LICENSED ELECTRICIAN.**

**THE RFLM-1 IS INTENDED TO BE INSTALLED BY PERSONS EXPERIENCED IN THE OPERATION OF LOW-VOLTAGE DEVICES. THE INSTRUCTIONS SUPPLIED, ALTHOUGH APPROPRIATE, DO NOT CONSTITUTE ANY ACCEPTANCE BY STEELCRAFT INC. FOR ANY LIABILITY FOR DAMAGES THAT MAY OCCUR THROUGH THE USE OF THESE INSTRUCTIONS.**

**IF THERE IS A CONFLICT BETWEEN THESE INSTRUCTIONS AND LOCAL ELECTRIC CODES, THE ELECTRICAL CODES SHALL ALWAYS TAKE PRECEDENCE.**

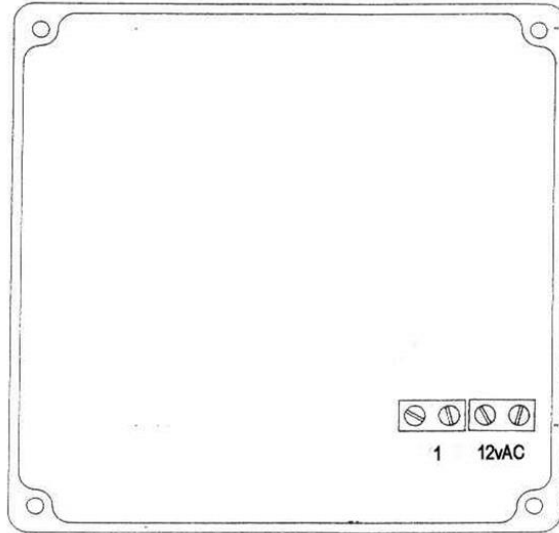

Figure 1: RFLM-1 Internal Connections

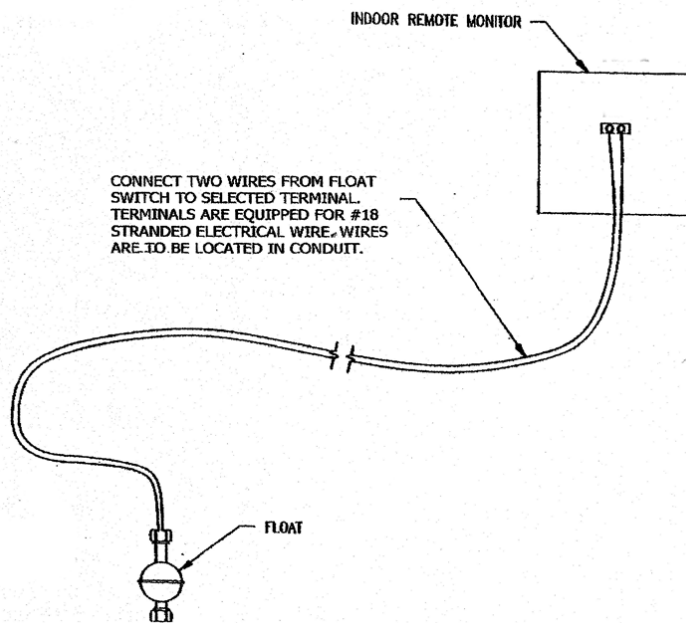

Figure 2: RFLM-1 Float Switch Wiring Diagram

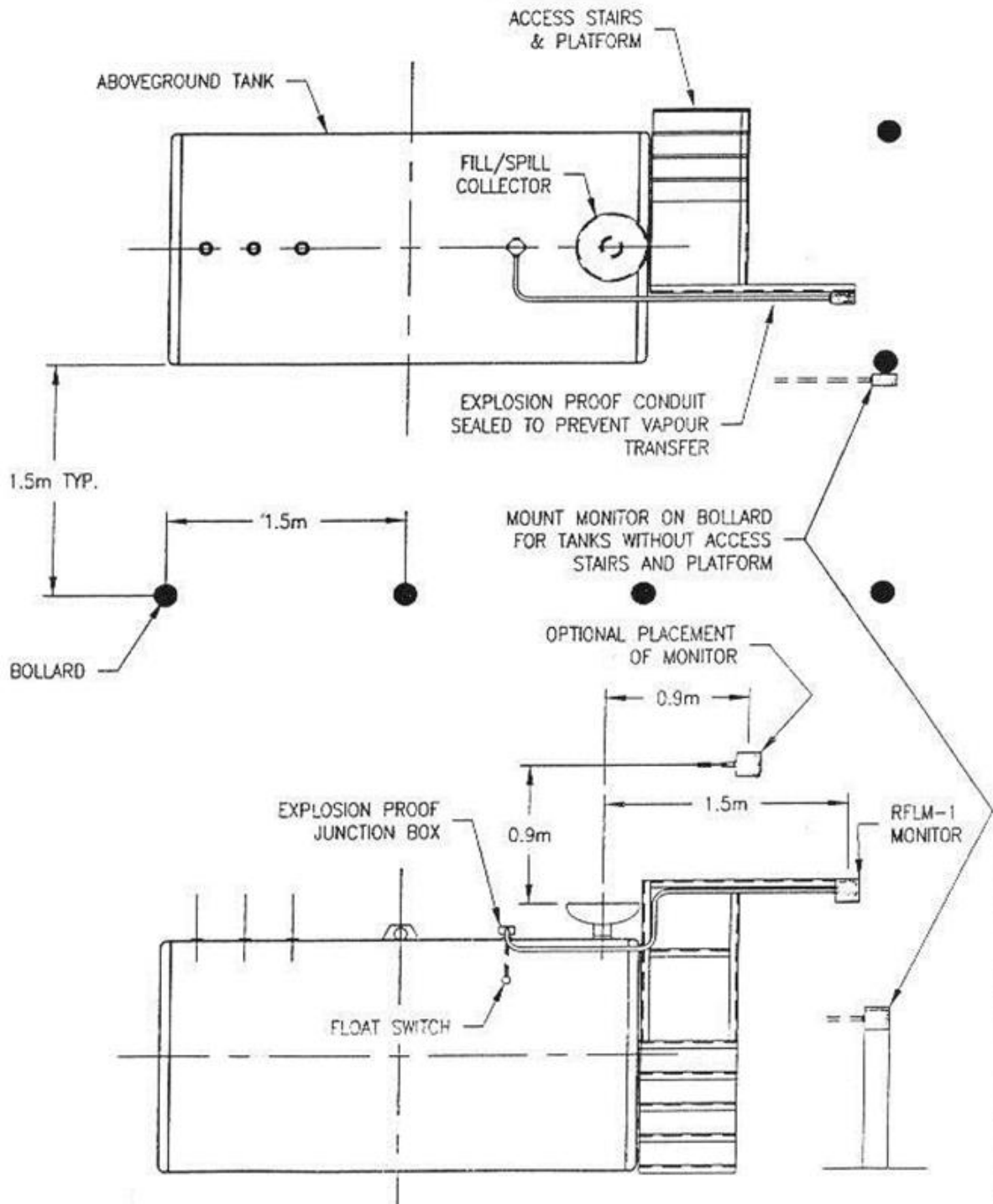

Figure 3: RFLM-1 Monitor Placement



## Filament & L.V. Rectifier Use

Power



### OPEN STYLE FILAMENT & L.V. RECTIFIER USE TRANSFORMERS

- Primary 115 VAC, 60 Hz.
- All secondaries center tapped, VAC (RMS)
- Open style, channel bracket, two hole chassis mount.
- Minimum 6" long leads.
- Dual bobbin design - no electrostatic shield required.
- Class B insulation (130 degrees, C)
- Hi-Pot test of 2,000V RMS.
- UL listed (# E50394) & CSA certified (# LR3902).

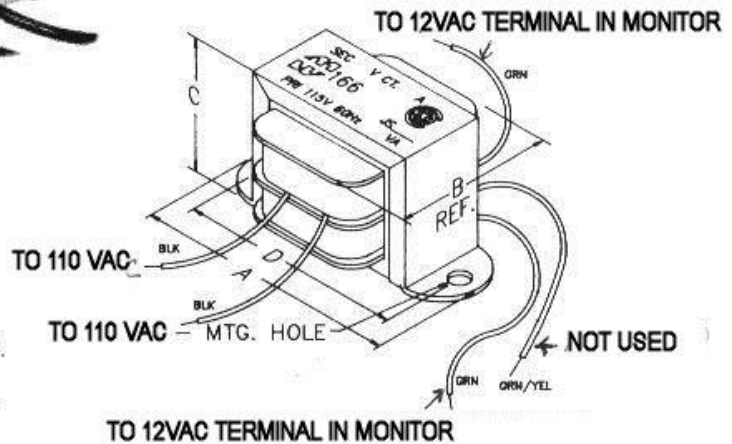

Dimension Table

Mtg. Style	Dimensions				Mtg. Hole
	A	B	C	D	
C0H	1.35	0.69	0.69	1.06	.125
C1H	1.63	0.88	0.81	1.38	.125
C2H	2.06	1.25	1.19	1.75	.187
C3H	2.06	1.38	1.19	1.75	.187
C4H	2.38	1.38	1.38	2.00	.187
C5H	2.38	1.50	1.38	2.00	.187
C6H	2.81	1.50	1.69	2.38	.187
C7H	2.81	1.63	1.69	2.38	.187
C8H	3.25	1.63	2.00	2.81	.187
C9H	3.25	1.75	2.00	2.81	.187
C10H	3.25	2.00	2.00	2.81	.187
C11H	3.69	1.88	2.31	3.13	.187
C12H	3.69	2.00	2.31	3.13	.187
C13H	3.69	2.13	2.31	3.13	.187
C14H	4.03	2.25	2.63	3.56	.187
C15H	4.03	2.50	2.63	3.56	.187
C16H	4.50	2.50	2.88	4.00	.203

### Transformer Schematic

